

VERTICAL INSPECTION SPREADER & spectra

TYRE TESTER

Provozní rozměry stroje

Dimensions of the machine in service.

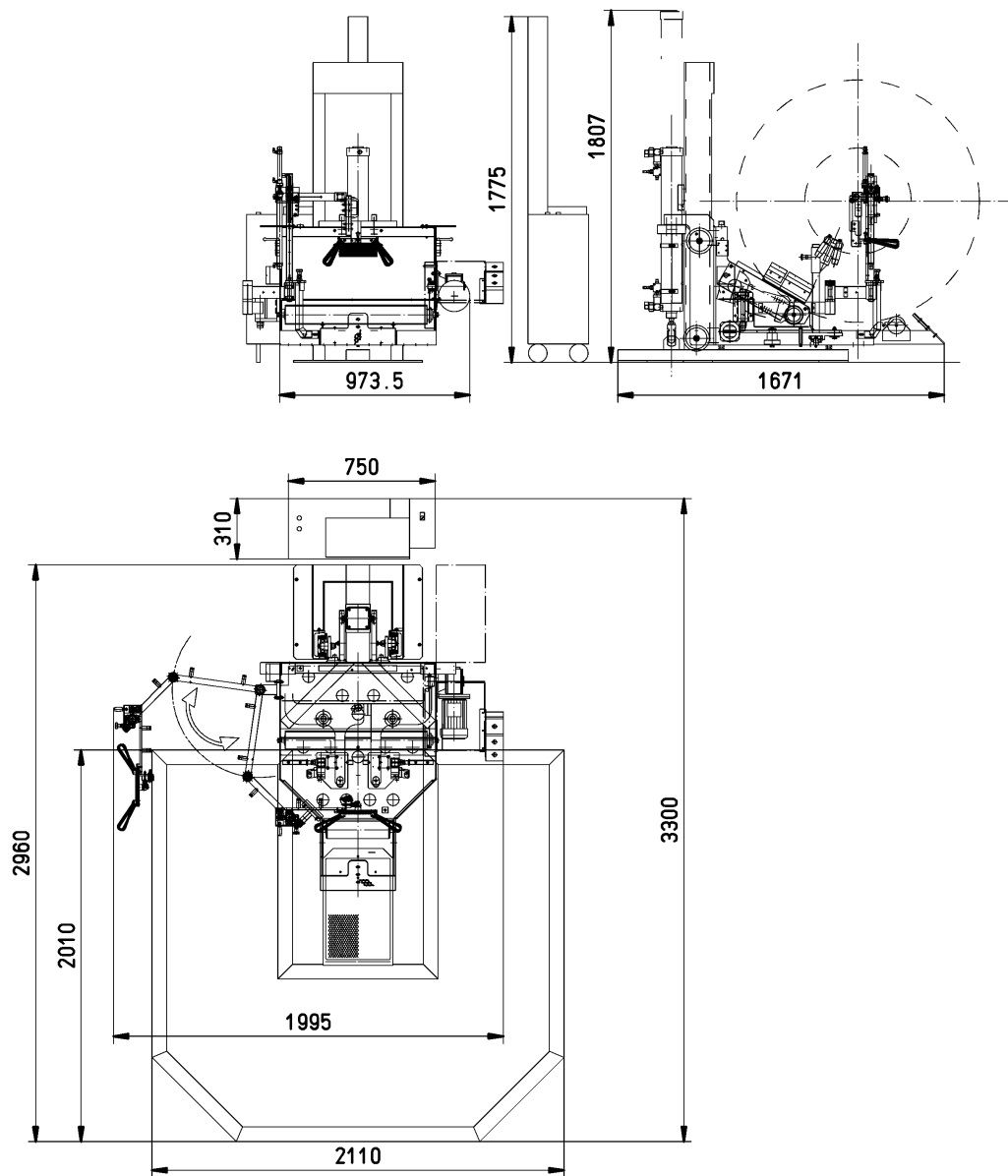

váha netto

net weight

480 kg

celkový příkon energie

total installed power

1,5 kW

spotřeba stlačeného vzduchu

compressed air absorption

200NI/cyklus cycle



matteuzzi srl

macchine per pneumatici e per i processi di ricostruzione
equipment for the tyre and retreading industries

